

END VIEW

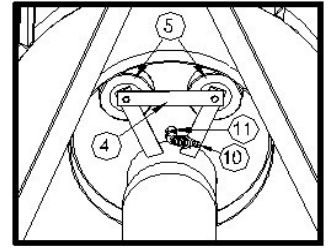

WHEEL ASSEMBLY VIEW

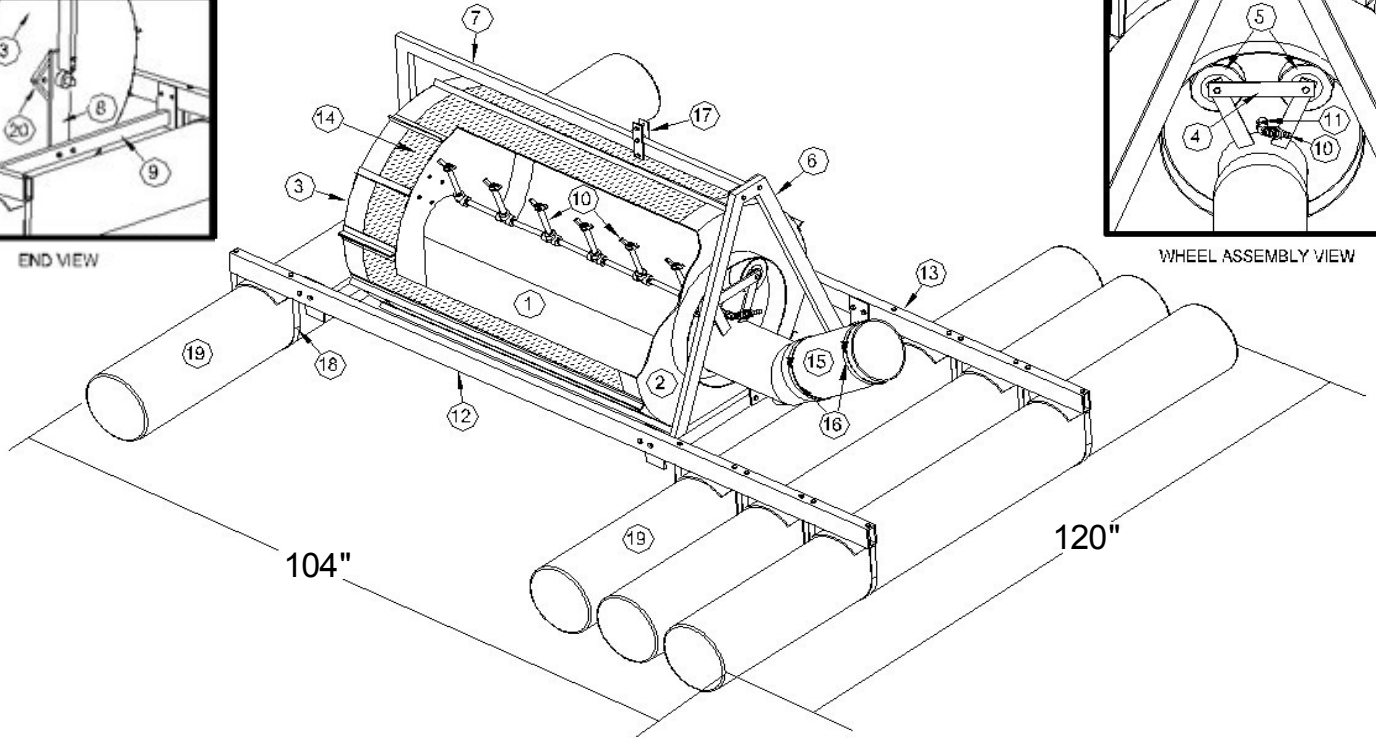

Parts List

Item	Part No.	Qty.	Description
1	R - SF1012	1	12" Suction Funnel
2	R - DPB0812	1	Drum Plate B
3	R - DPA0812	1	Drum Plate A
4	R - WB1012	1	10" Wheel Bracket
5	WA500	2	Wheel Assembly
6	R - AF0812	1	A Frame
7	R - LF0812	1	L Frame
8	R - DSP0812	1	Drum Support Plate
9	R - DSR0812	1	Drum Support Rail
10	R - CSB0812	1	Cleaning Spray Bar
11	R - SBA0612	1	Spray Bar Attachment
12	R - LR0812	1	Left Side Rail
13	R - RR0812	1	Right Side Rail
14	R - SA0812	2	Screen Assembly
15	SH012	1	12"x40" Suction Hose
16	TBC012	2	12" T Bolt Clamp
17	R - HP001	1	Hanger Plate
18	R - PS0612	8	Pontoon Strap
19	R - P10	4	10 ft. Pontoon
20	FPL205-AIB-1-6	1	1" Bearing w/ Block

Specifications

Weights

Basic Unit: 285 lbs
Optional Equipment
 Power Drive: 2 lbs
 Foot Valve w/ Pressure Relief: 16 lbs
 Extra pontoon: 24 lbs

Maximum GPM Ratings & Velocities

4,000 GPM @ 11.66 ft per second
 3,000 GPM @ 8.75 ft per second
 2,000 GPM @ 5.83 ft per second
 1,000 GPM @ 2.91 ft per second

Screen area at maximum depth (7 inches)
 8.29 Square feet

Additional Set-up Items (Not Shown in Picture)

EPDM58	1	5/8" Hose
R - FA0612	1	Filter Assembly
CC6252	1	Anchor
AR1550	1	Cable
R - BP0612	1	Bolt Package